

# NEWSLETTER

of the  
**Dandenong Valley Historic Car Club Inc.**

**October - 2024**  
**Volume 51 - No. 3**



**[www.dvhcc.com.au](http://www.dvhcc.com.au)**  
**P.O. Box 107, Doveton 3177**

**Print Post Approved**  
**PP 100001488**



**Est. February 1974**



# DANDENONG VALLEY HISTORIC CAR CLUB INC.

## Incorporation No. A0000748U



\*\*\* 2024 CAR OF THE YEAR \*\*\*  
1928 Chevrolet National tourer - Ern & Pam Hopgood

### DANDENONG VALLEY HISTORIC CAR CLUB INC. (DVHCC)

is a member of

The Federation of Veteran Vintage & Classic Vehicle Clubs Victoria (FVVCVC) and  
The Association of Motoring Clubs (AOMC)

The DVHCC Caters for vehicles manufactured prior to 31 December 1942.

Website: <http://www.dvhcc.com.au>

The next meeting will be

***the General Meeting which will be held at the,  
Dandenong Agricultural Society Club Rooms.  
on Friday 4th October 2024.***

Dandenong Showgrounds, Bennet Street, Dandenong.

Enter through the Main Gate, follow the bitumen to the end and turn right.

Doors open at 7.30pm, - Meeting commences at 8.00pm



Newsletter Cover Sponsored by Shannons Insurance Ph. 13 46 46

# Across the Editor's Desk

## Contents:

1. Across the Editor's Desk
2. Committee Page
3. President's report.
- 4/5. September 2024 G M Minutes
6. Coming events
7. Weekend Away -  
# IMPORTANT NOTICE.#
7. Cleaning Roster.
- 8/11. Elfin Heritage Centre
- 12/13. Marong Car Show.
14. Pedestrian safety.
15. People Catchers.
16. Easy Recipe for you to try.
17. MG Y Type Advert.
18. Funnys
19. WANTED.
20. Club Merchandise
21. Advertisers

Hi Everyone,

I wasn't far wrong with the temperature comment last month as we have had some lovely days with the temperature up as high as 29 degrees. I thought the ground was drying up, but no such luck. We had more heavy rain and I bogged my 1940 Chev again trying to get it into it's garage. The wind has been ferocious with wind speeds up to more than 110km/h.

I want to thank Gary S. for all the photos of the visit to the Elfin Heritage Centre and the other venues and Len M. for the report on the day. What an interesting day it must have been with 3 different places to visit. Thanks to Marg D. for the attendance list as well.

Micheal Cogley sent the photos and report on the Federation's Marong picnic day, thanks Micheal. Do you like the cover this month? It is one of Marg D's. photos from Old Gippsdown. Thanks Marg and to Kevin C. for the great cover. Thanks also to Ian.C, Jim L. and to John J. for the other items in this months Newsletter. What a great number of Newsletter submissions. It makes my job as Editor so much easier to do when there is something to include each month.

John J. sent the story on the People Catchers and whilst I was looking to Mr. Google for more info and help, he gave me a sticky reply about modern People Catchers which you will find on page 14.

Your new committee is up and running with banking changes and other things keeping them awake at night like fitting in with the Club's Rules of Association..

Regards and best wishes to you all, Rick.

Newsletter Cover  
Design:  
Gary Stocking

Newsletter Deadline  
14th of EVERY  
MONTH

Email contributions to  
The Editor

Cover Page Sponsored by



**SHANNONS**

[www.shannons.com.au](http://www.shannons.com.au)

13 46 46

DISCLAIMER: The committee of the Dandenong Valley Historic Car Club Inc. and its members accept no responsibility for the views and opinions expressed in this Newsletter or for the accuracy of the information contained within and are not liable for any incidents or damage that may arise from information contained within.

# DVHCC Inc. Committee



**PRESIDENT:**  
John Jenkins

Mobile: 0443 886 109  
Email: [president@dvhcc.com.au](mailto:president@dvhcc.com.au)



**VICE-PRESIDENT:**  
Kevin Clarence

Mobile: 0417 553 613  
Email: [vicepresident@dvhcc.com.au](mailto:vicepresident@dvhcc.com.au)



**SECRETARY & PUBLIC OFFICER:**  
James Lang

Mobile: 0412 539 717  
Email: [secretary@dvhcc.com.au](mailto:secretary@dvhcc.com.au)



**TREASURER:**  
Brian Jelliff

0417 313 422  
Email: [treasurer@dvhcc.com.au](mailto:treasurer@dvhcc.com.au)



**CLUB CAPTAIN:**  
Marg Detez

Mobile: 0407 780 421  
Email: [clubcaptain@dvhcc.com.au](mailto:clubcaptain@dvhcc.com.au)



**EDITOR:**  
Rick Cove

Mobile: 0401 278 233  
Email: [editor@dvhcc.com.au](mailto:editor@dvhcc.com.au)



**COMMITTEE PERSON:**  
Leigh Howes

Mobile: 0413 883 763  
Email: [committeeperson@dvhcc.com.au](mailto:committeeperson@dvhcc.com.au)

## REPRESENTATIVES

Publicity Officer:-

Gary Stocking 0418 140 844  
[publicity@dvhcc.com.au](mailto:publicity@dvhcc.com.au)

Safety & CPS Officer:-

Leigh Howes 0413 883 768  
Assistant Safety & Permit Officer  
Irwin Sinclair 0438 905 574  
[permit@dvhcc.com.au](mailto:permit@dvhcc.com.au)

Webmaster:-

Kevin Clarence 0417 553 613  
Ben MacDonald 0431 525 615  
[web@dvhcc.com.au](mailto:web@dvhcc.com.au)

Federation VVC/C Reps:-

Max Hobson 0424 223 040  
Paul Tangy 0418 627 650  
[federation@dvhcc.com.au](mailto:federation@dvhcc.com.au)

AOMC Reps:-

Rick Cove 0401 278 238  
Ian Clark 0419 312 304  
[aomc@dvhcc.com.au](mailto:aomc@dvhcc.com.au)

.....  
Sub-committees:-

Scoresby Picnic.

[picnic@dvhcc.com.au](mailto:picnic@dvhcc.com.au)  
Gary Stocking 0418 140 844  
Len Mizzi 0403 230 641  
Ray Griffin 0409 216 273  
Michael Cogley 0425 875 116

.....  
Please refer to your Club Register for home phone numbers and addresses



# President's Report October 2024

Recently I have had the pleasure of attending two 80th birthday celebrations of DVHCC members. They were my long-time friend, Bev Sinclair, and also Les Francis, who I have known for 17 years. Both chose a commercial venue with elegant facilities and a good menu. The best part was the wonderful company of about 40 people at each.

At each function, friends and family were present, and it occurred to me that, if Car Club people had been excluded, then attendance would have been very much less. This emphasizes the value of our Car Club. Our Club I consider to be based on friendship, companions and people with a common interest in old vehicles.

It was in the mid 1980's that Irwin Sinclair introduced me to the Cadillac Club, and then in 2006, he invited me to join the DVHCC. The result of which is that my circle of friends would otherwise have been far less.

Research shows us that socially isolated people have a reduced life expectancy. Did you know that that is another advantage of DVHCC membership?

According to our last Register, 17 members do not have a pre-1943 car. That is fine by me, as for various reasons, some people are not in the position to drive or own a pre-1943 car. I regard the friendship of these 17 people as rewarding as I do the others. Further to that some persons such as Don Jones (lots) and Paul Tangy (Federation Rep) have contributed so much to the Club.

Advancing time may see more members choose a not so old post-1942 car. Heavy clutches and stiff steering may induce some older members to merely admire their Club car, rather than drive it. My own car can always accommodate such people as passengers, and they are welcome anytime. I know that other members are always likewise pleased to provide transport. Please ask us should we overlook to offer you a ride.  
John..

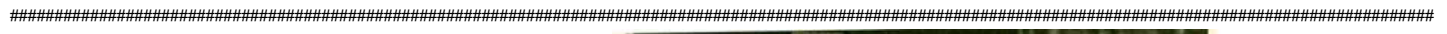

## PEOPLE CATCHERS. By John Jenkins.

(Look for this article further inside  
on page 15.)

### A "Man-Catcher."

This safety device consists of three rollers attached to the radiator of the vehicle. Directly the rollers touch an obstacle, they automatically drop to the ground and push it away.



A "MAN-CATCHER."  
This safety device consists of three rollers attached to the radiator of the vehicle. Directly the rollers touch an obstacle, they automatically drop to the ground and push it away.

# 4. Minutes of General Meeting of the Dandenong Valley Historic Car Club held on the 6th September 2024.

Meeting opened 8.03 with President John Jenkins in the chair.

**Apologies:** Rick and Jill Cove, Amanda Eagles, Lindsay Tharle, Aub Smith, Margaret Griffin, Margaret and Stan Snyders, Greg Strafford, Roger Bowen, Eric Hickmott, Sandra and Michael Cogley, Bryron and Janice Savoury, Paul and Lyn McMillan, Ron and Pam Barnett

**Minutes Motion:** The minutes of the July General Meeting published in the August newsletter be accepted as accurate. Moved Ray Griffin Seconded Peter Lafrank Passed

## **Secretaries Report –**

### **August 2024 Inward correspondence**

- Casey Council – events forum
- Bay to Birdwood registrations - selling out fast by 2
- VDC – B40 Rally to Warragul
- AOMC B40 rally
- AOMC – Clubs and Traders Showcase October 26
- AOMC country delegates meeting by 2

### **Advertising Flyers**

- Coorang Reality
- Rare Spares by 3
- MotorEx by 2
- Shannons by 4
- Antique Tyres
- Micawber Tavern by 2
- Grays online auctions
- Cascade Art Maldon by 2
- Online Auto parts by 2
- Print for U
- Flags and Banners
- Visit Hamilton by 3
- Penrite
- Bend Motor Sport by 1
- Retromotive Magazine by 2
- Auto Equip by 2

4 Club Magazines by email

6 Club Magazines by Post

### **August 2024 Outward correspondence – nil**

**Motion:** that the inwards correspondence is received, and outward correspondence approved for the month of August 2024. Moved Don Jones Seconded Ray Griffin Passed

**Treasurer's Report –** Brian presented financial results Motion Moved Brian Jeliff Seconded Bev. Sinclair Passed

### **Federation Report – Meeting in Mildura:**

- Need volunteers for Bendigo Swap gates plus Swap sites still available
- Peter Mac fund raiser was just over \$5000 last year
- Outlined problems with VicRoads and for clubs to keep a copy of their registered office bearers
- Tax office have a telephone inquiry service you can use instead of using the paper form to determine if you need to pay tax
- Provided details of the Golden Oldies Tour next year plus an Open Tour from Kerang to Horsham

**Motion:** that the inwards correspondence is received, and outward correspondence approved for the month of August 2024. Moved Don Jones Seconded Ray Griffin Passed

**Treasurer's Report –** Brian presented financial results Motion Moved Brian Jeliff Seconded Bev. Sinclair Passed

### **Federation Report – Meeting in Mildura:**

- Need volunteers for Bendigo Swap gates plus Swap sites still available
- Peter Mac fund raiser was just over \$5000 last year
- Outlined problems with VicRoads and for clubs to keep a copy of their registered office bearers
- Tax office have a telephone inquiry service you can use instead of using the paper form to determine if you need to pay tax
- Provided details of the Golden Oldies Tour next year plus an Open Tour from Kerang to Horsham

**Minutes of General Meeting of the  
Dandenong Valley Historic Car Club held on the 6th September 2024.**

**AOMC Report** – nil

**Editor Report** – nil

**Scoresby Picnic** – Gary Stocking agreed to be leader and to be assisted by Michael Cogley, Ray Griffin and Len Mizzi

**Weekend Away:**

- We need more to apply to attend, and bookings need to be confirmed by early October – see Ian
- John is looking into maybe hiring a minibus to make it easier for people to get there. The cost of minibus is around \$160 (\$1500 in total) per couple for a 25 seater. Not many people showed interest in the mini bus – see John if interested

Jim presented the Committee's proposal re budget strategy now that the swap has finished. Broad approval was given so the committee can work out details in coming months

**Past Events.**

- Irwin Sinclair – Old Moe town – good day – good roll up of cars – well worth the trip
- Leigh Howes – Glen Huntley car show – excellent day – good collection of cars – well organized – good atmosphere – only problem was lack of toilets – organisers have invited us to return next year

**Future Events**

- 8th September - Elfin Museum – well worth the visit
- 6th October - Caldermeade Farm – if want to take the tractor tour – please advise John as they need the numbers
- 3rd November Dandenong Show

**Australia Day Car Show** – nil

**Web Master Report** – nil

**General Business.**

- Jim asked to write to Akoonah Park to cancel our booking and have our funds returned
- Heather has agreed to send out cards for those that are sick – please advise John if you know of anyone that is ill
- Ian – funny story re finding gold at Sovereign Hill
- Graham Bates – father's day Holden display – great traditional event
- Don Jones – spare swap meeting sites – see Don
- Irwin – Ian Stuchbery in care, and looking to sell his Stutz
- Gary – Scoresby picnic flyers for people to hand out
- Jim asked for volunteer for next meeting – Gary volunteered
- Still looking for volunteer to bring first aid kit each month
- Leigh Howes – outlined various small engine displays in different country towns over the next couple of months

**Car or Parts for Sale** - nil

- **Ray Griffin** – 2 Hillmans 34 and 38 models – see Ray – low price to a good home
- **Roger Bowen** – several cars in particular a 1933 Chev Master Sedan

Meeting Closed 8.58

**Jim Lang** Secretary

**John Jenkins** President

**6th. October. Sunday. Caldermere Farm And Cafe. 4385 South Gippsland Highway. Caldermere.**

Caldermere is a fully operating commercial dairy farm that also educates and entertains visitors. The cafe provides indoor and outdoor dining. Some products offered for sale are Jersey milk, goat milk, butter, cheese, yogurt and ice cream. There is an animal nursery, and you may view the milking procedure.

Schedule. Arrive at 10 AM. Cars will be parked in a dedicated area. Entry is free. At 10—30, we may have a private tractor tour which will give general information of the business. The cost for the tractor tour is \$20 for adults, and \$12-50 for 4 to 12 children. I must confirm the booking for the tractor tour 7 days prior. Please notify me early of your interest in the tractor tour. This event will also suit your children/grandchildren.  
John Jenkins. 0448 886 109

**16th October Wednesday.** Manhattan Restaurant. Cnr. Heatherdale & Canterbury Rds. Ringwood. Meet there at 12 PM.

**21st and 22nd. October. (Monday 21st and Tuesday 22nd.) Come and camp at Noogee.**

Bring your camper, caravan or tent. Meet 10 AM at Service Centre, Officer. We will depart the Princess Hwy before Drouin and pass the Robin Hood hotel which will lead us thru Neerim and to Noogee. Eight km from Noogee is Toorongoo campground. Bring your fire wood and walking shoes. Itinerary includes historic trestle bridge, Noogee steam train and history display, walks to 2 waterfalls and trout farm.

## **NOVEMBER.**

**1st November. Friday . General meeting at Myuna Farm.** 182 Kidds Rd. Doveton. Arrive at 5-30 or 6 PM. BYO dinner and cups. BBQ will be available.

**13th November. Wednesday . Bear House Restaurant.** 110 Sloden St. Cranbourne.  
Meet there at 12 PM.

**17th November. Sunday. Dandenong Show.** (info still coming.)

**8th December.** Christmas at the residence of Kevin and Carol Clarence.

2025.

**5th January Sunday.** Twilight Run. Yet to be organised.

**26th January 2025. "DVHCC Australia Day Car Show."**

South Eastern Masonic Centre Keysborough, \$20.00 per car.

**9th February Sunday.** Stamford Park Homestead. Rowville. Yet to be organised.

**9th March Sunday.** Yet to be organised. (Long weekend?)

**20th. to the 24th. March DVHCC Weekend Away.** Albury-Wodonga area. Please let Heather or Marg D. know if you are attending.

**27th April 27. Sunday.** Scoresby Picnic.



# WEEKEND AWAY - IMPORTANT INFORMATION

**20th. to the 24th. March 2024**  
*DVHCC Weekend Away.* Albury-Wodonga area.

**If you intend joining us on the weekend away in Albury next March from Thursday 20th to Monday 24th 2025, can you please let Heather or Marg know at our October meeting at the very latest.**

**We have to book the motel rooms we required in the first week in October.**

## DVHCC Clean Up Roster

MONTH	MEETING	KITCHEN	HALL
Friday 6 September	General Meeting at DAS Clubrooms.	Myra Capes	Sam Capes
Friday 4 October	General Meeting at DAS Clubrooms.	Carole Carless	Frazer Carless
Friday 1 November	General Meeting and BBQ at Myuna Farm	Everyone	Everyone
Friday 6 December	General Meeting at DAS Clubrooms.	Sally Carson	Bill & Carson

If you are unable to attend please let us know by phone or email: [committee@dvhcc.com.au](mailto:committee@dvhcc.com.au)



***Just how fast was the little bloke going?***

# Triple Treat Sunday..

Our September Sunday run turned out to be quite an excursion.

Firstly, we went into the Elfin Heritage Centre. At the Elfin Centre we were greeted by Bill Fleming, who knows everything there is to know and do about Elfin Cars. After a quick look around, Bill spoke to us about the origins and present workings of his company. Bill makes Elfin cars to order and he is in demand. Bill told us of a famous Australian racing driver named Garrie Cooper who blitzed the racing circuits from 1958 through to the 1970's.

The first things that hits your eyes, when you walk in, is the huge quantity of memorabilia placed over every wall and on every shelf. You see photos of past and some present drivers, model cars and engines, ranging from four to eight cylinders. I personally liked the many glass cabinets with collector cars and badges on display.

On the floor you see cars, racing cars, frames and bodies, and I must mention tools including a hoist and other equipment. It looks a very tidy and well-organized place.

Upstairs you find more cars like Volkswagen variants, Alpha Romeo's and of course more Elfin cars. I asked Bill how the cars get to the top floor as there is no ramp as such. He said he lifts each car up there with his fork lift. Simple hey?

We were then invited to go over the road and see Nigel Tait. Nigel is a Repco man and is the president of the Repco Club. He is a racing car driver as well as the owner of some historic race cars. He spoke to us on his history and experiences in racing and restoring.

After Nigel's place, we were invited to go the factory a couple of doors further down, where there was a display of race cars, motor bikes and rally cars.

We had a cuppa and enjoyed each other's company. It was windy, but the sun shone for us. Some members went home and others continued on and had lunch at the Cheltenham RSL.

It was another great run. Well done to the organizers.

by Len Mizzi.

## **Club Vehicles**

Leigh Howes 1931 Chev  
John Jenkins 1936 Cadillac  
Gary Stocking 1934 Plymouth  
Ray Nichol 1939 Pontiac  
Peter Lafrank 1929 Chev  
Irwin and Bev Sinclair 1940  
Cadillac  
Max Hobson and Tess 1938 Ford  
Sam and Myra Capes 1939 Chev

## **Vehicles of Interest**

George Ray Peugeot 504  
Len Mizzi 1967 MGB  
Marg Detez 1949 MGY

## **Modern**

Graeme Chard  
Don Fleiner  
Jeanie and Max Tuckerman  
Brian Jelliff  
Graham and Sue Bates  
Jim and Cici Lang  
Kevin and Carol Clarence  
Ron and Pat Sinclair.





# The Elfin Heritage Centre 8th September 2024







**ELFIN HERITAGE CENTRE**  
*Keeping the Spirit Alive*

## ELFIN CLUBMAN

1961-1965

The Clubman Chassis was based on the Elfin Streamliner. Of the 14 built, the first 2 production models used swing axle front suspension. All the other cars were fitted with unequal length wishbones.

The Clubman was a popular introduction for many into Motorsport, and the Elfin was generally more effective than overseas versions.

The basic design of the Clubman vehicles has stood the test of time, and the new Elfin Clubman Type 3 was introduced in 1998 with 70 cars being produced up until 2008.

**Display Vehicle**  
Chassis # 1621 is the second Elfin Clubman to be built. Originally sold as a kit, this car was extensively modified and raced by its second owner, Greg Mobbs, to achieve a third placing in the South Australian Sports Car Championship. The car was restored in 1982 by Elfin historian and author John Blanden.

Wheelbase: 225 cm  
Front Track: 125 cm  
Rear Track: 122 cm  
Overall length: 323 cm  
Weight: 8 - 8 1/2 cwt













# 13 Marong Car Show and Golden Oldies Tour start. by Michael C.

It was a great day for the Federation Marong Car Show, a car show which included the Federation Golden Oldies Tour. The Federation Golden Oldies Tour which went from Marong to Maryborough, then Ballarat, Daylesford and further on. There were 55 cars taking part in what would have been a great tour.





*There's nothing new under the sun.*

## Google Patents Sticky Car Hood to Trap Pedestrians

Google Patents Sticky Car Hood to Trap Pedestrians in a Collision  
The human flypaper is designed to mitigate injuries when a car, person collide.

**ABC News**  
**May 20, 2016, 12:58 AM**

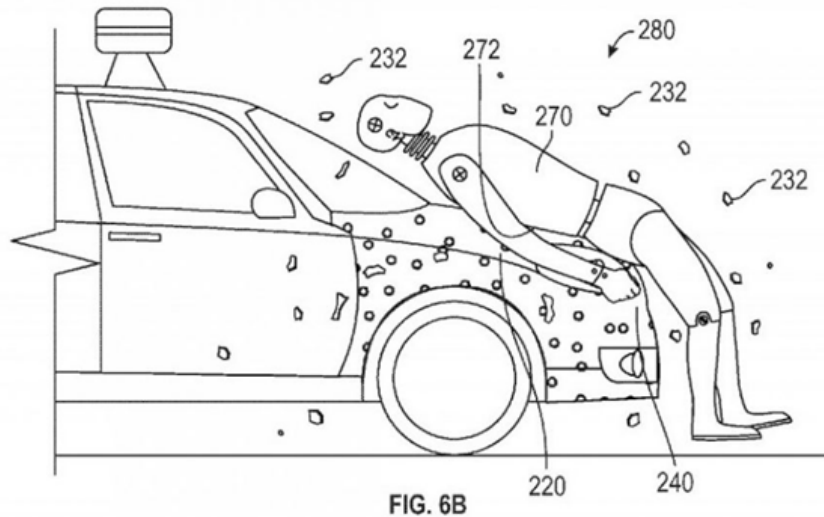

This is an illustration from a patent application shows the operation of an adhesive that Google hopes will help mitigate injuries when a car strikes a pedestrian.

In a patent issued this week, the search giant describes a “system for protecting a colliding object from a secondary impact, after an initial impact with a vehicle.”

The patent calls for a giant sticker to be placed on the front end of a vehicle, with a special coating over the layer that is only broken when something collides with the vehicle, exposing the adhesive and helping the colliding object to remain on the vehicle.

The idea is to prevent a pedestrian from being thrown after the impact and potentially sustaining even more injuries. “In the event of a collision between a vehicle and a pedestrian, injury to the pedestrian is often caused not only by the initial impact of the vehicle and the pedestrian, but also by the ensuing, secondary impact between the pedestrian and the road surface or other object,” Google writes in the patent.



## PEOPLE CATCHERS from JJ. (and Rick.)

EVER SINCE LONDONER BRIDGET DRISCOLL became the first pedestrian to die in an automobile accident in 1896, *(The death of Bridget Driscoll (c.1851 – 17 August 1896) was the first recorded case of a pedestrian killed in a collision with a motor car... You can re-read all about it in the DVHCC Newsletter, July 2023. Volume.49 No.12...ED)*, the authorities said, "That this must never happen again." Road deaths since have reached astonishing numbers. In the USA for example, the National Agency estimates that 40,990 people died in motor vehicle traffic crashes in 2023, a decrease of about 3.6% as compared to 42,514 fatalities reported to have occurred in 2022. World-wide, the figure had decreased slightly to 1.19 million road deaths. (Don't ask me how many persons were injured by motor vehicles during the same time period.)

In the 1930's, one invention, aimed to solve the problem, was the 'People Catcher'. In front, or incorporated within the front bumper-bar, was a people scoop. When the driver saw an errant pedestrian, he would activate a lever, which would, in turn, deploy a large catcher. All being well, the catcher would collect the wayward pedestrian and prevent him from passing under the car.

Some trucks were also fitted with a more elaborate catcher. The deployed catcher tracked the ground on rollers with the intention of catching or deflecting the pedestrian away from the wheels.

As late as the seventies, a sloping bonnet behind a concealed bar was fitted by auto maker. The bar released after impact with the pedestrian who was expected to be caught atop the bonnet. The bar prevented him from sliding off the bonnet and so passing under the car.

*(Unfortunately, I cannot find any reference to that particular article. ED.)*



### This Roller Safety Device Sweeps Away Fallen Pedestrian

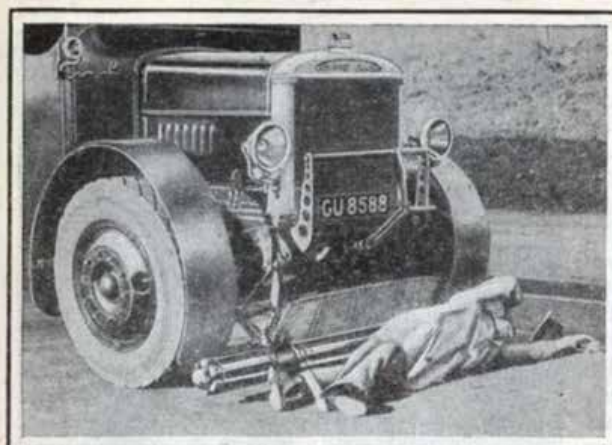

This new safety device, consisting of a shield and roller geared to the motor, sweeps the man ahead till the truck comes to a halt.

**T**RUCKS equipped with the new safety device shown in the photo at the left will literally sweep a fallen pedestrian before it and thus save him from being crushed to almost certain death beneath the heavy wheels. The device consists chiefly of a grooved roller mounted on an extension arm in front of the wheels and geared to the engine.

On coming in contact with a fallen pedestrian it tends to roll him ahead till the truck can be brought to a stop. Ordinarily, it projects out in front of the car, serving as a bumper, but is released immediately by the driver when there is a possibility of an accident.



# Banana Brownies

## Banana Brownies

### Ingredients:

- 1/4 cup unsalted butter
- 4 oz white chocolate
- 2 medium mashed bananas
- 1/2 cup granulated sugar
- 1 egg
- 1/4 teaspoon salt
- 1 teaspoon vanilla extract
- 1 cup all purpose flour

### Directions:

Preheat oven to 350

In a large microwave-safe bowl, melt the butter and white chocolate in 30 second bursts, stirring each time until melted. Stir in the sugar. Mix in the mashed bananas, Add eggs, salt, and vanilla and stir until well combined. Mix in the flour until completely incorporated.



Spread batter into a 8" square pan and bake 15-20 minutes or until tester comes out clean. Cool completely and store covered.





# Versatility

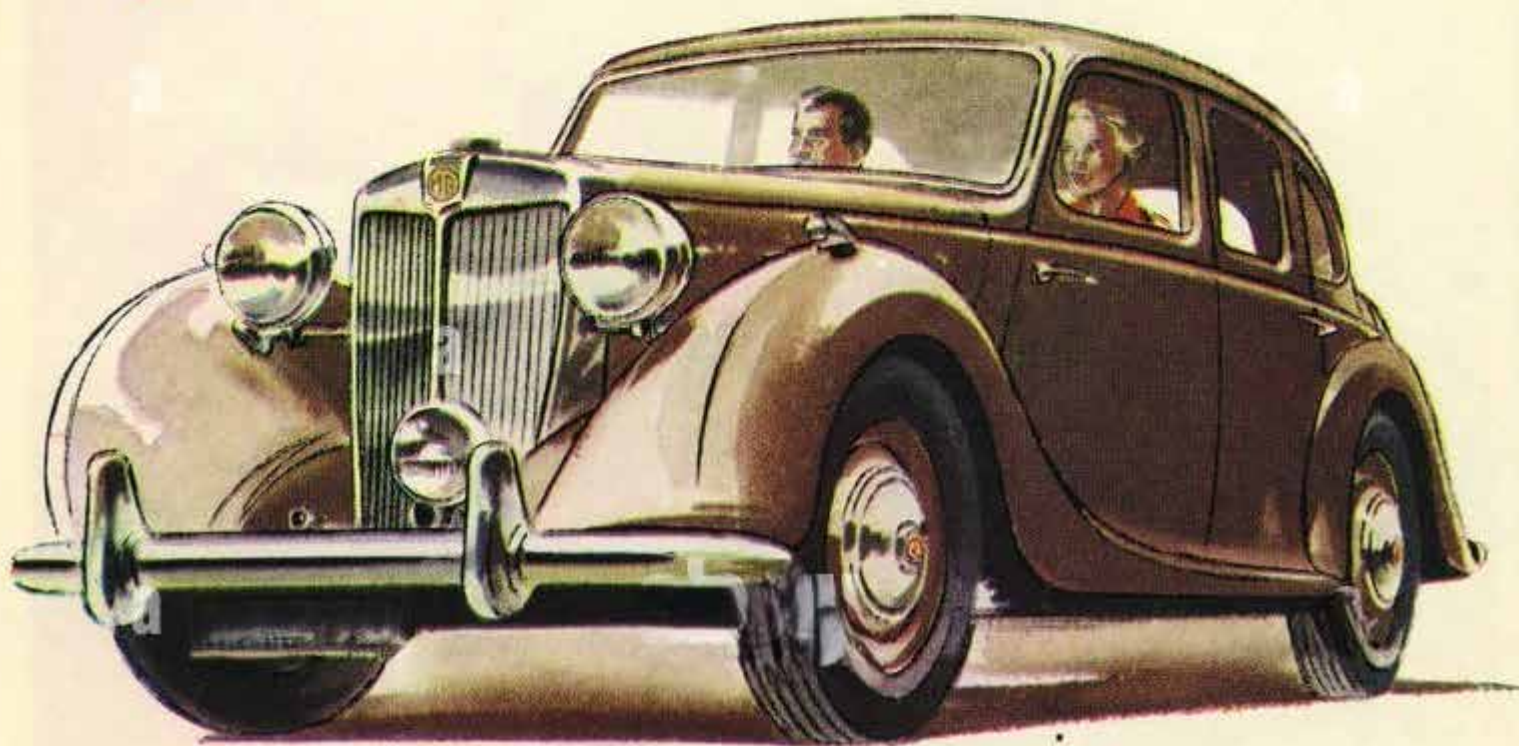

*Here is a car that solves the problem of exciting the sports motorist as well as delighting his family. This comfortable and good-looking M.G. saloon never demurs at crawling in town traffic: nor, on the other hand, does it shy at 75 m.p.h. on the open road. A race-winning engine and a handsome saloon body combine to make it the family car with a sporting heart.*

*Features include . . .*

- Wish-bone type independent front wheel suspension
- Piston-type hydraulic dampers
- Powerful hydraulic brakes
- Walnut facia panel
- Finest grade leather upholstery

*One and a quarter*

LITRE



SALOON

*Safety fast!*

THE M.G. CAR COMPANY LIMITED, SALES DIVISION, COWLEY, OXFORD  
London Showrooms: University Motors Ltd., Stratton House, 80 Piccadilly, W.1  
Overseas Business: Nuffield Exports Ltd., Oxford and 41 Piccadilly, London, W.1







'It's utterly ridiculous spending so much money on this tiny old car when you can no longer drive it'

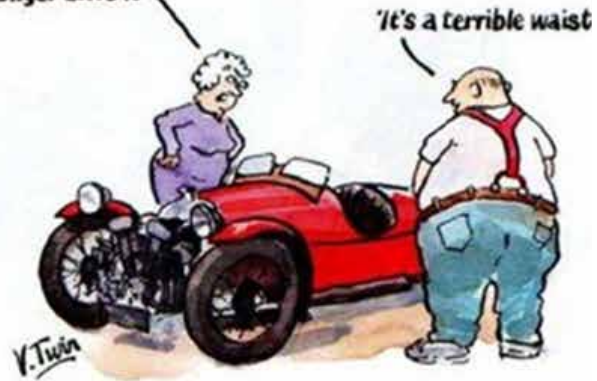

State of  
**NERVOUSNESS**

Bureau of  
**NUISANCES**

LICENSE NUMBER  
**18-2597**

THE COMMISSIONER ALREADY HAS YOUR NUMBER, BUT WE'VE ASSIGNED THIS ONE TO YOU ANYWAY!

**BACK SEAT DRIVER'S LICENSE**

NAME \_\_\_\_\_  
Print In Full

ADDRESS \_\_\_\_\_

CITY \_\_\_\_\_ ZONE \_\_\_\_\_ STATE \_\_\_\_\_

Signature of Licensee \_\_\_\_\_

THIS IS TO CERTIFY THAT THE PERSON HEREIN NAMED HAS PASSED ALL TESTS FOR NERVOUSNESS AND HAS BEEN LICENSED TO IRRITATE, ANNOY, CRITICIZE, AND OTHERWISE DISTURB THE OPERATOR OF THE CAR.

DATE ISSUED  
**1960-64**

EXPIRES WHEN REGULAR DRIVER'S LICENSE IS ISSUED

ISSUED BY:  
*G. M. J. Nervous*  
Commissioner of Nervous Wrecks  
DEPT. OF INTERIOR CONFUSION

BACK SEAT DRIVER MUST CARRY THIS LICENSE ON PERSON. OTHERWISE MUST KEEP QUIET WHILE VEHICLE IS IN MOTION.



'It's easy to tell the difference between Morgan men...  
... The three-wheeler owners wash their hands before they go to the toilet.'

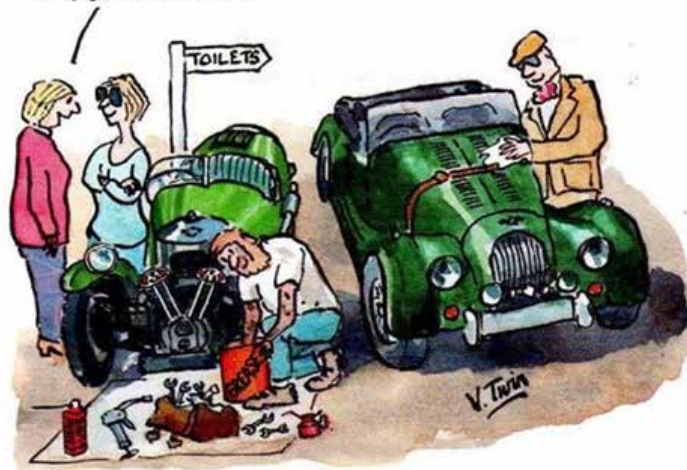



# WANTED

OLD STYLE TURNING INDICATOR SWITCH suitable for the Rugby

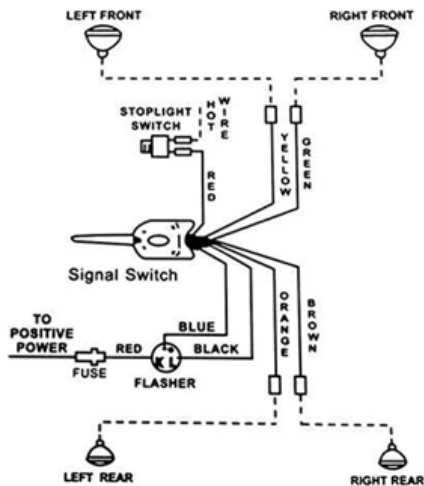

WIRING DIAGRAM

*Please contact  
Lindsay Tharle.  
ph. 0413 690 020  
if you can help out.*

# Club Merchandise

To purchase items, please see the Committee Person at the next General Meeting

CLUB SHIRT  
\$25



POLO SHIRT  
\$28



CLUB MUG  
\$9



*Are you wearing your Club outfit?  
Nothing looks better than you, in the correct outfit, on display at an event.*

CLUB CAP  
\$9



WIND CHEATER  
\$40



DECAL STICKER  
\$1



CLOTH BADGE  
\$3.50



BUMPER BADGE  
\$21



LAPEL BADGE  
\$6





# CENTRE ROAD BATTERIES



PH 9546 6000  
 FAX 9546 6001  
 MOBILE 0402 01 07 96

CNR Westall & Brear Street  
 SPRINGVALE 3171

www.centreroadbatteries.com.au  
 Deep Cycle Specialists **Danny Rault**



paul vermont  
 paul@vinwire.com.au  
 p. (03) 9870 0583



## vintage wiring harness

po box 2288 ringwood victoria 3134 | www.vinwire.com.au



# Fountain Gate AUTO ELECTRICS

Brad Allen

P: 9705 1181 F: 9705 1732  
 admin@fgateautoelectrics.com.au  
 PO Box 1119 Vesper Drive, Narre Warren, VIC 3805  
 Fact 5, Cnr Princes Hwy & Vesper Dve, Narre Warren, VIC 3805  
 www.fountaingateautoelectrics.com.au



# JEFF'S SERVICE CENTRE

SERVICING ALL TYPES OF VEHICLES  
 MINOR AND MAJOR REPAIRS

LATEST  
 DIANOSTIC  
 EQUIPMENT

**JEFF VASSALLO**  
 www.jeffsservicecentre.com.au

PH: 9546 8506 Mobile: 0407 511 622  
 3-401 Princes Highway, Noble Park Vic. 3174  
 (On Service Rd between Chandler & Fintonia Roads)  
 Fax: 9547 5498



# AUTO SURPLUS

VETERAN | VINTAGE | CLASSIC

## ALL THE PARTS YOU NEED FOR YOUR VETERAN, VINTAGE OR CLASSIC VEHICLE

ENGINE & DRIVELINE | BRAKE & CLUTCH  
 STEERING & SUSPENSION | ELECTRICAL & IGNITION



# A.A. VINNEY'S

www.vinneys.com.au

Metal Polishers & Electroplaters  
 24 - 26 Short Street, Dandenong, 3175

Vince & Anna  
 Di Blasio

Ph: (03) 9794 7530  
 Fax: (03) 9794 7532



*'It's The Finish That Counts'*

www.autosurplus.com.au

Unit 18, 114 Merrindale Drive, Croydon South VIC 3136  
 03 9873 3566  
 sales@autosurplus.com.au

# Grant White Motor Trimmer

Specialising in:  
 Vintage &  
 Classic Cars



93 LYON ROAD  
 VIEWBANK 3084  
 PH: 9458 3479  
 E: grantwhite@dodo.com.au





“NO ONE KNOWS YOUR  
PASSION LIKE SHANNONS.”



Shannons Home and Comprehensive Car and Bike insurance is for motoring enthusiasts just like you, with features like:

- Choice of repairer
- Agreed value
- Multi-Vehicle & Multi-Policy discounts
- Limited Use & Club Plate cover
- Laid up cover
- One excess free windscreen claim per year
- Total loss salvage options
- Home & Contents Insurance including \$10,000 enthusiast items cover for your collectables & tools
- Towing & storage costs as a result of loss or damage
- Pay by the month premiums at no extra cost

Call Shannons on **13 46 46** for a quote on your special car, daily drive, bike or your home, and speak with a genuine enthusiast.



Join the Shannons Club today! Get connected and share your passion - [shannons.com.au/club](http://shannons.com.au/club)



**SHARE THE PASSION**

**INSURANCE FOR MOTORING ENTHUSIASTS | CALL 13 46 46 FOR A QUOTE | SHANNONS.COM.AU**

Shannons Pty Limited ABN 91 099 692 636 is an authorised representative of AAI Limited ABN 48 005 297 807, the product issuer. Some benefits only apply to comprehensive vehicle cover. Shannons has not taken account of your objectives, financial situation or needs. Read the Product Disclosure Statement before buying this insurance, available at [shannons.com.au](http://shannons.com.au). The Target Market Determination is also available. Terms, conditions, limits and exclusions apply. The type of cover must be specified on your certificate of insurance. If you do not use your vehicle in accordance with the vehicle usage shown on your policy certificate you may not be covered in the event of a claim. Discounts do not apply to the optional Shannons Roadside Assist or CTP. SHFMA2101 17/9/21 A